

# AMC-TJ1

## DATASHEET

A benchtop Test Jig for development and production work on AdvancedMC boards

Facilitates easy access to circuitry for fault finding or debug during board operation

AMC Fabric Interface connections provide off-board connectivity.

Also suitable for Boundary Scan Testing

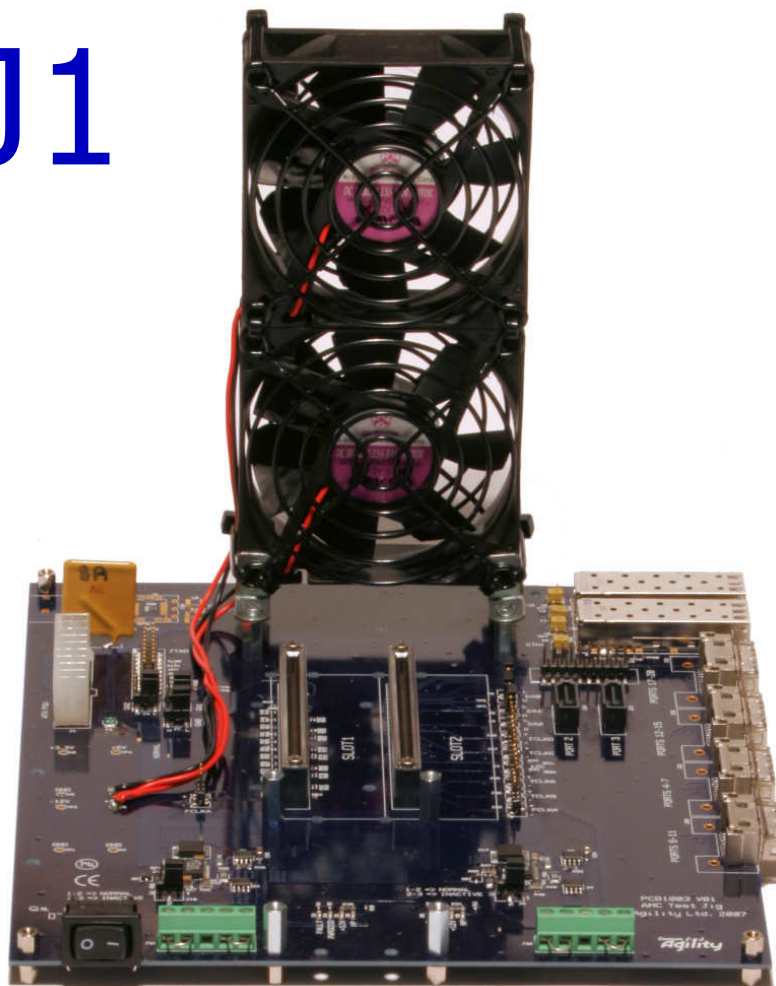

### KEY FEATURES

- ◆ Full AMC JTAG test capability
- ◆ Loopback functional test capability
- ◆ Interface test capability
- ◆ External IPMB bus connector
- ◆ External JTAG connector
- ◆ Current monitoring and control
- ◆ Cooling fan included
- ◆ Bench top with vertical AMC mounting.
- ◆ AMC connectors bolted down, not soldered.

### RESULTING BENEFITS

- ☞ Connectivity and build quality test
- ☞ Simple self-contained functional test
- ☞ test & debug all interfaces
- ☞ MMC testing
- ☞ Allows use of preferred JTAG controller
- ☞ avoids damage to AMC
- ☞ Allows AMC to run at higher power
- ☞ Easy insertion; full debug access to AMC
- ☞ Sacrificial connector for production use, allows easy change

The CommAgility AMC-TJ1 is a comprehensive bench-top test harness for Advanced Mezzanine Cards, allowing easy configuration and access to external AMC ports. There are two test slots, with functions as follows:

Slot 1 is designed for JTAG testing. All AMC ports (except Ethernet) are loop-back connected on the PCB which is ideal for testing AMCs and their external interfaces in a production environment.

Slot 2 is designed for functional testing. This slot has all AMC ports connected to headers or off-board connectors, e.g. SFP modules for Ethernet, SATA connectors and Infiniband style ports for the fat pipes and extended options. This allows an AdvancedMC module to be fully functionally tested by connecting appropriate cables and equipment to the AMC-TJ1. Alternatively, by using 2 x AMC-TJ1 and cables, a full back-to-back functional test of two AdvancedMC modules can be performed.



CommAgility Ltd  
Loughborough, UK

sales@commagility.com  
www.commagility.com

Tel: +44 1509 228866  
Fax: +44 8452 991150

Comm ( )  
**Agility**

# CommAgility

## HARDWARE SPECIFICATIONS

### Slot 1:

- ♦ Supports Full-height, double width AMCs
- ♦ 12V @ 5A, 3.3V @ 0.41A
- ♦ All AMC ports looped-back on the PCB (Ethernet optional)
- ♦ External JTAG TAP controller header
- ♦ Ethernet SFP socket (optional)
- ♦ Geographic Address Jumpers
- ♦ Boundary Scan control of power

### Slot 2:

- ♦ Supports Full-height, double width AMCs.
- ♦ 12V @ 5A, 3.3V @ 0.41A
- ♦ External JTAG TAP controller header.
- ♦ SFP sockets for Ethernet (Ports 0 & 1)
- ♦ SATA connectors (Ports 2 & 3)
- ♦ Infiniband style ports for the fat pipes and extended options on AMC ports 4-7, 8-11, 12-15 & 17-20
- ♦ IPMB controller connector (for example, Pigeon Point development card)

### Other:

- ♦ Standard ATX power supply connector.
- ♦ Bolt-on (sacrificial) AdvancedMC connectors for easy replacement in a production test environment
- ♦ Geographic address for each slot set via jumper links
- ♦ Unmanaged Hot Swap control with current limiting circuitry and protection against incorrect AMC insertion
- ♦ limited cooling for AMC slots provided by side fan tower

## OTHER COMMAGILITY PRODUCTS

CommAgility is primarily focused on the development of Advanced Mezzanine Cards for OEM customers involved in high performance signal processing, in wireless, imaging and other applications. There are a range of state of the art DSP and FPGA-based products available. Please use the website and contact information below for further details.

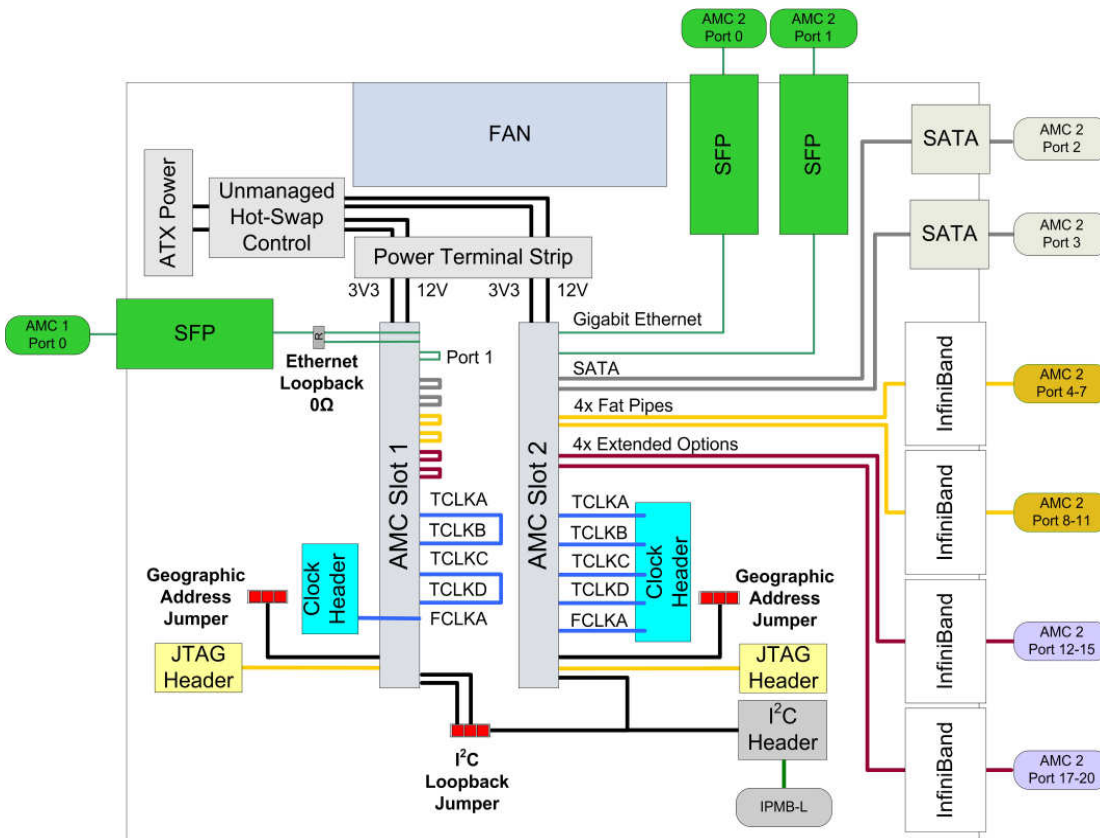

# AMC-TJ1

OEM SERVICES AVAILABLE

**IN DEVELOPMENT:**  
support and training; hardware customisation; software and FPGA development.

**IN MANUFACTURE:**  
leadtime reduction through stocking components or products; extended warranty and repair; quick turn repairs and/or spares stocking. Licensing of designs considered for high volumes.

**OVER LIFECYCLE:**  
obsolescence management; guaranteed lifecycle; design information held in Escrow.



CommAgility Ltd  
Loughborough, UK

sales@commagility.com  
www.commagility.com

Tel: +44 1509 228866  
Fax: +44 8452 991150

